

VSG01 - 300PSI Grooved-End Y Type Strainer

- Installed in both Horizontal or Vertical Line with Upward Flow
- Easier and Faster to Maintain and Install
- Low Pressure Drop

Material Specifications

1. Body: Ductile Iron ASTM A536

Standard Surface Finish: FBE coated interior and exterior

Standard Color: Red RAL3000 / Blue RAL5015

Option: Hot dip galvanized

2. Screen: Stainless Steel 304, Perforated metal

Standard: 2 – 3"(DN50 – 80): 0.062"(1.6mm) diameter perforations.

4 – 12"(DN100 – 300): 0.125"(3.2mm) diameter perforations.

Option: 2 – 12"(DN50 – 300): 0.315"(8mm) diameter perforations.

Other perforation available upon request

3. Grooved Coupling:

Housing: Material: Ductile Iron ASTM A 536

Standard Surface Finish: Hot dip galvanized

Other material or finish available upon request

Rubber Gaskets:

Standard:

Grade "E" EPDM (Color code: Green stripe)

Temperature range -30°F to +230°F (-34°C to +110°C). Recommended for cold and hot water service within the specified temperature range plus a variety of dilute acids, oil-free air and many chemical services. NOT RECOMMENDED FOR PETROLEUM SERVICES.

Option:

Grade "T" Nitrile (Color code: Orange stripe)

Temperature range -20°F to +180°F (-29°C to +82°C). Recommended for petroleum products, air with oil vapors, vegetable and mineral oils within the specified temperature range. Not recommended for hot water services over +150°F (+66°C) or for hot dry air over +140°F (+60°C).

Other material available upon request

Bolts/Nuts: Heat treated carbon steel zinc electroplated to ASTM B633, track head conforming to physical properties of ASTM A183 minimum tensile 110,000 psi/758340 kPa.

4. Grooved Cap: Ductile Iron ASTM A536

Standard Surface Finish: Hot dip galvanized, Other material or finish available upon request

5. Plug: Malleable Iron ASTM A197 / A47

Standard Surface Finish: Hot dip galvanized

Threaded: NPT pipe threaded, Other threaded available upon request

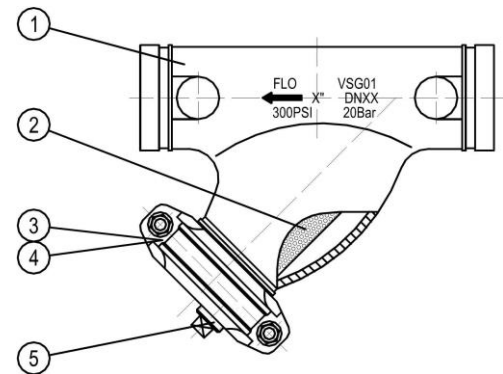

Y TYPE STRAINER



VSG01 - 300PSI Grooved-End Y Type Strainer

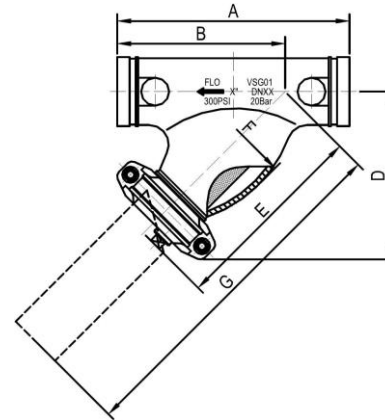
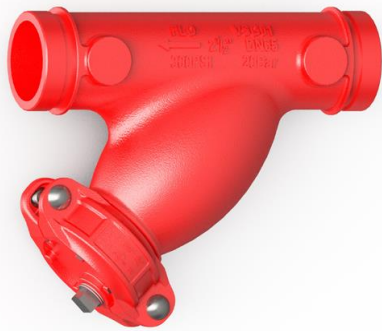

Dimension

Part Number	size		OD mm	A		B		D		E		F		G		Plug in.	Weight	
	in.	mm		in.	mm	in.	mm	in.	mm	in.	mm	in.	mm	in.	mm		lbs	kg
VSG01-060	2	50	60.3	9.75	248	7.00	178	7.00	178	8.54	217	3.50	89	13.58	345	1/2	10.0	4.5
VSG01-073	2 1/2	65	73.0	10.75	273	7.75	197	7.83	199	9.32	237	4.13	105	15.04	382	1/2	14.0	6.4
VSG01-076	2 1/2	65	76.1	10.75	273	7.75	197	7.87	200	9.32	237	4.13	105	15.04	382	1/2	14.0	6.4
VSG01-089	3	80	88.9	11.75	299	8.50	216	8.50	216	10.14	258	4.75	121	16.26	413	3/4	20.0	9.1
VSG01-114	4	100	114.3	14.25	362	10.50	267	10.87	276	12.72	323	6.25	159	21.30	541	1	32.0	14.5
VSG01-140	5	125	139.7	16.50	419	12.50	318	12.75	324	14.36	365	7.88	200	23.43	595	1	50.0	22.7
VSG01-141	5	125	141.3	16.50	419	12.50	318	12.75	324	14.36	365	7.88	200	23.43	595	1	50.0	22.7
VSG01-165	6	150	165.1	18.50	470	14.00	356	13.82	351	16.06	408	9.25	235	26.61	676	1 1/4	72.0	32.7
VSG01-168	6	150	168.3	18.50	470	14.00	356	13.90	353	16.06	408	9.25	235	26.61	676	1 1/4	72.0	32.7
VSG01-219	8	200	219.1	24.00	610	18.00	457	17.76	451	20.31	516	12.38	315	34.09	866	1 1/2	125	56.7
VSG01-273	10	250	273.0															
VSG01-324	12	300	323.9															

Y Type Strainer Performance Date

Formulas for C_v Values

$$\Delta P = \frac{Q^2}{C_v^2}$$

$$Q = C_v \times \sqrt{\Delta P}$$

Where: Q = Flow rate (gallons per minute: GPM)

ΔP = Pressure drop across valve (PSI)

C_v = Flow coefficient

