

GATE VALVE



VGG105 - 300PSI Grooved-End Gate Valve

- Bolted Bonnet • Non-Rising Stem • Resilient Wedge • Grooved-End
- 300 PSI / 20.7Bar Non-Shock Cold Working Pressure
- Conforms to AWWA C509
- FBE Coated Interior and Exterior
- Maximum Operating Temperature 185°F / 85°C
- FM Approved & UL/ULC Listed

Material Specifications

PART	SPECIFICATION
1. Valve Body	Ductile Iron ASTM A536
2. Resilient Wedge	Ductile Iron ASTM A536 with EPDM Encapsulation
3. Wedge Nut	Bronze ASTM B584 UNS C83600
4. Stem	Stainless Steel ASTM A276 UNS S41000
5. Bonnet Gasket	EPDM
6. Bonnet Screw	Alloy Steel ASTM A574 Zinc Plated
7. Bonnet	Cast Iron ASTM A126-B
8. Stem Primary O-Ring	EPDM
9. Stem Thrust Washer	Stainless Steel ASTM A276 UNS S41000
10. Gland Seal O-Ring	EPDM
11. Stem Ring Wiper	EPDM
12. Operating Nut Washer	Carbon steel Zinc Plated
13. Operating Nut Screw	Alloy Steel ASTM A574 Zinc Plated
14. Square Operating Nut	Cast Iron ASTM A126-B
14A. Handwheel (Optional)	Ductile Iron ASTM A536
15. Stem Primary O-Ring	EPDM
16. Stem Seal Bushing	Brass ASTM B16 UNS C36000

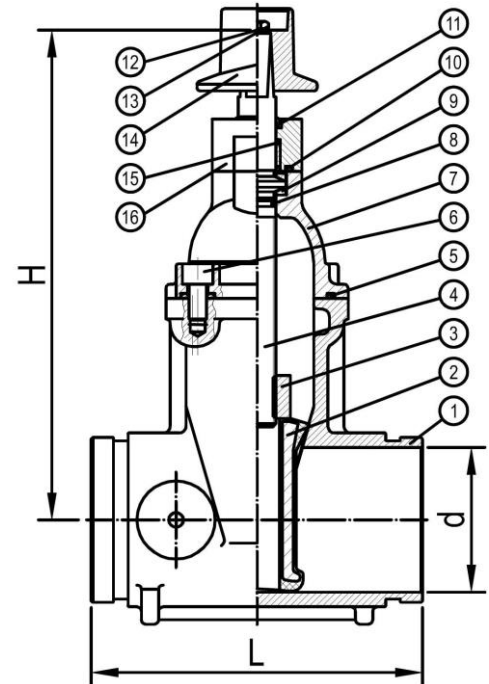

Dimension

Part Number	Size		L		d		H		Turns To Open
	in.	mm	in.	mm	in.	mm	in.	mm	
VGG105-073 VGG105-076	2.5	65	7.5	190	2.5	64	11.6	295	8.1
VGG105-089	3	80	8.0	203	3.0	76	12.7	322	10
VGG105-114	4	100	9.0	229	4.0	102	13.9	353	12.5
VGG105-165 VGG105-168	6	150	10.5	267	6.0	152	17.6	447	15
VGG105-219	8	200	11.5	292	8.0	203	20.8	529	16.7
VGG105-273	10	250	13.0	330	10.0	254	24.4	619	20.8
VGG105-324	12*	300	14.0	356	12.0	305	27.8	707	25
VGG105-356	14*	350	15.0	381	13.3	337	31.8	808	43.8
VGG105-406	16*	400	16.0	406	15.2	387	34.2	869	50

Note:

- ◆ Freezing Weather Precaution-Subsequent to testing a piping system, valves should be in an open position to allow complete drainage.
- ◆ *: Non-Shock Cold Working Pressure is 250PSI / 17.2Bar.

