



VGFG138 - 300PSI Flanged x Grooved-End Gate Valve

- Bolted Bonnet • Outside Screw and Yoke • Resilient Wedge • Flanged X Grooved-End
- 300 PSI / 20.7Bar Non-Shock Cold Working Pressure
- Conforms to AWWA C509
- FBE Coated Interior and Exterior
- Maximum Operating Temperature 185°F / 85°C
- FM Approved & UL/ULC Listed

Material Specifications

PART	SPECIFICATION
1. Valve Body	Ductile Iron ASTM A536
2. Resilient Wedge	Ductile Iron ASTM A536 with EPDM Encapsulation
3. Wedge Nut	Bronze ASTM B584 UNS C83600
4. Dowel Pin	Stainless Steel ASTM A276 UNS S42000
5. Stem Back Seat O-Ring	EPDM
6. Bonnet Gasket	EPDM
7. Bonnet	Ductile Iron ASTM A536
8. Stem Packing	EPDM
9. Threaded Rod	Carbon steel Zinc Plated
10. Gland Bushing	Brass ASTM B584
11. Gland	Cast Iron ASTM A126-B
12. Gland Nut	Stainless Steel 18-8
13. Yoke Screw	Alloy Steel ASTM A574 Zinc Plated
14. Yoke	Cast Iron ASTM A126-B
15. Yoke Bushing	Bronze ASTM B584
16. Flat Point Set Screw	Alloy Steel ASTM F912 Black Oxide
17. Yoke Bushing Retainer	Cast Iron ASTM A126-B
18. Handwheel	Ductile Iron ASTM A 536
19. Handwheel Nut	Carbon steel Zinc Plated
20. Flat Head Screw	Carbon steel Zinc Plated
21. Stem	Bronze ASTM B150 UNS C61400
22. Bonnet Screw	Alloy Steel ASTM A574 Zinc Plated

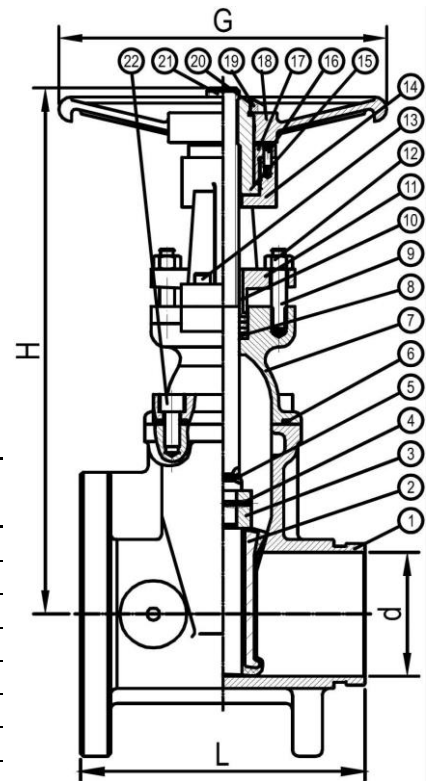

Dimension

Part Number	Size		L		d		G		H(open)		H(close)		Turns To Open
	in.	mm	in.	mm	in.	mm	in.	mm	in.	mm	in.	mm	
VGFG138-065	2.5	65	7.5	190	2.5	64	7.9	200	18.8	478	16.2	411	8.1
VGFG138-080	3	80	8.0	203	3.0	76	7.9	200	20.3	515	17.1	434	10
VGFG138-100	4	100	9.0	229	4.0	102	10.2	260	22.1	562	18.2	462	10
VGFG138-150	6	150	10.5	267	6.0	152	12.4	315	29.4	747	23.5	597	15
VGFG138-200	8	200	11.5	292	8.0	203	14.8	375	36.8	934	28.6	727	16.7
VGFG138-250	10	250	13.0	330	10.0	254	16.4	416	45.2	1147	35.1	891	20.8
VGFG138-300	12*	300	14.0	356	12.0	305	17.5	445	52.2	1326	40.2	1020	25
VGFG138-350	14*	350	15.0	381	13.3	337	19.7	500	62.7	1592	48.3	1226	43.8
VGFG138-400	16*	400	16.0	406	15.2	387	19.7	500	66.2	1682	50.7	1288	50

Note:

- ◆ Freezing Weather Precaution-Subsequent to testing a piping system, valves should be in an open position to allow complete drainage.
- ◆ Flange: ANSI Class125&150, other flange dimensions are available.
- ◆ *: Non-Shock Cold Working Pressure is 250PSI / 17.2Bar.

