

VCW01 - 300PSI Wafer Check Valve

- Installed in both Horizontal or Vertical Line with Upward Flow
- Easier and Faster to Maintain and Install
- Low Pressure Drop
- EPDM non-stick leak tight sealing
- All Stainless Steel Wetted Parts to Provide Superior Corrosion Resistance



Material Specifications

PART	SPECIFICATION
1. Body	ASTM A536
2. Seat	EPDM / NBR
3. Disc	CF8M / C954 / DI
4. Spring	ASTM A276 302
5. Stem	ASTM A582 416
6. Gasket	EPDM / NBR

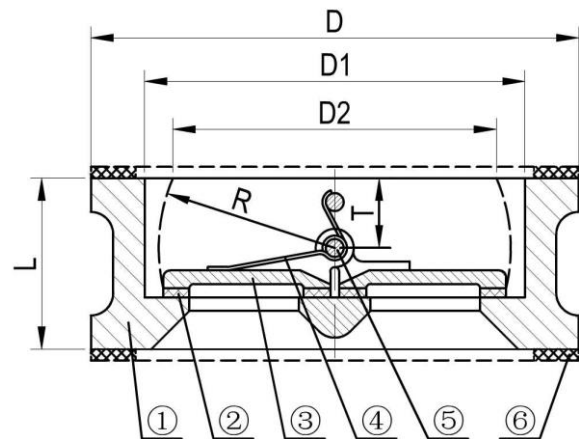

Dimension

Part Number	SIZE		D		D1		D2		L		R		T		Weight	
	in.	mm	in.	mm	in.	mm	in.	mm	in.	mm	in.	mm	in.	mm	lbs	kg
VCW01-050	2	50	4.21	107	2.56	65	1.70	43.3	1.69	43	1.13	28.8	0.75	19	3.30	1.5
VCW01-065	2½	65	5.00	127	3.15	80	2.37	60.2	1.81	46	1.42	36.1	0.79	20	5.29	2.4
VCW01-080	3	80	5.59	142	3.70	94	2.61	66.4	2.52	64	1.71	43.4	1.10	28	7.93	3.6
VCW01-100	4	100	6.38	162	4.61	117	3.57	90.8	2.52	64	2.08	52.8	1.06	27	12.6	5.7
VCW01-125	5	125	7.56	192	5.71	145	4.60	116.9	2.76	70	2.59	65.7	1.18	30	16.1	7.3
VCW01-150	6	150	8.58	218	6.69	170	5.69	144.6	2.99	76	3.09	78.6	1.22	31	19.8	9.0
VCW01-200	8	200	10.75	273	8.82	224	7.80	198.2	3.50	89	4.11	104.4	1.30	33	37.4	17
VCW01-250	10	250	12.91	328	10.43	265	9.20	233.7	4.49	114	5.00	127.0	1.97	50	57.3	26
VCW01-300	12	300	14.88	378	12.20	310	11.18	283.9	4.49	114	5.84	148.3	1.69	43	92.5	42