

VCG01 - 350PSI Grooved-End Swing Check Valve

- Installed in both Horizontal or Vertical Line with Upward Flow
- Easier and Faster to Maintain and Install
- Low Pressure Drop
- EPDM non-stick leak tight sealing
- All Stainless Steel Wetted Parts to Provide Superior Corrosion Resistance
- FM Approved & UL/ULC Listed



Material Specifications

PART	SPECIFICATION
1. Body	Ductile Iron ASTM A395
2. Clapper	Stainless Steel 304
3. Facing Seal	EPDM Rubber
4. Seat	Bronze
5. Clamping Ring	Stainless Steel 304
6. Gasket	EPDM Rubber
7. Spring	Stainless Steel 304
8. Hinge Pin	Stainless Steel 304
9. Bolt	Stainless Steel 304
10. Locknut	Stainless Steel 304
11. Plug 1/4" NPT	Carbon Steel
12. Plug 1/2" NPT	Carbon Steel
13. Nameplate	Stainless Steel

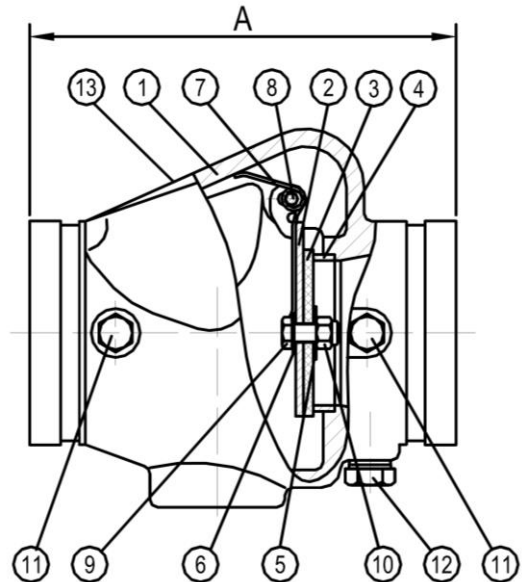

Dimension

Part Number	Size		OD mm	A		B		Weight	
	in.	mm		in.	mm	in.	mm	lbs	kg
VCG01-060	2	50	60.3	6.65	169	3.54	90	5.5	2.5
VCG01-073	2 1/2	65	73.0	7.20	183	3.86	98	8.8	4
VCG01-076	3OD	65	76.1	7.20	183	3.86	98	8.8	4
VCG01-089	3	80	88.9	7.80	198	4.29	109	13	6
VCG01-114	4	100	114.3	8.58	218	4.80	122	20	9
VCG01-140	5 1/2 OD	125	139.7	9.76	248	5.39	137	33	15
VCG01-141	5	125	141.3	9.76	248	5.39	137	33	15
VCG01-165	6 1/2 OD	150	165.1	10.63	270	5.83	148	42	19
VCG01-168	6	150	168.3	10.63	270	5.83	148	42	19
VCG01-219	8	200	219.1	12.80	325	7.28	185	77	35



CHECK VALVE



Check Valve Performance Date

Formulas for C_v Values

$$\Delta P = \frac{Q^2}{C_v^2}$$

$$Q = C_v \times \sqrt{\Delta P}$$

Where: Q = Flow rate (gallons per minute: GPM)

ΔP = Pressure drop across valve (PSI)

C_v = Flow coefficient

Nominal Size	Pipe O.D.	Cv (Full Open)	Nominal Size	Pipe O.D.	Cv (Full Open)	Nominal Size	Pipe O.D.	Cv (Full Open)
In.	mm	mm	In.	mm	mm	In.	mm	mm
2	50	60.3	4	100	114.3	6 1/2 OD	150	165.1
2 1/2	65	73.0	5 1/2 OD	125	139.7	6	150	168.3
3 OD	65	76.1	5	125	141.3	8	200	219.1
3	80	88.9						

