

### VCF01 - 350PSI Flanged Swing Check Valve

- Installed in both Horizontal or Vertical Line with Upward Flow
- Easier and Faster to Maintain and Install
- Low Pressure Drop
- EPDM non-stick leak tight sealing
- All Stainless Steel Wetted Parts to Provide Superior Corrosion Resistance
- UL/ULC Listed



#### Material Specifications

PART	SPECIFICATION
1. Body	Ductile Iron ASTM A395
2. Seat	Bronze
3. Clapper	Stainless Steel 304
4. Facing Seal	EPDM Rubber
5. Clamping Ring	Stainless Steel 304
6. Gasket	EPDM Rubber
7. Spring	Stainless Steel 304
8. Hinge Pin	Stainless Steel 304
9. Bolt	Stainless Steel 304
10. Locknut	Stainless Steel 304
11. Plug 1/4" NPT	Carbon Steel
12. Plug 1/2" NPT	Carbon Steel
13. Nameplate	Stainless Steel

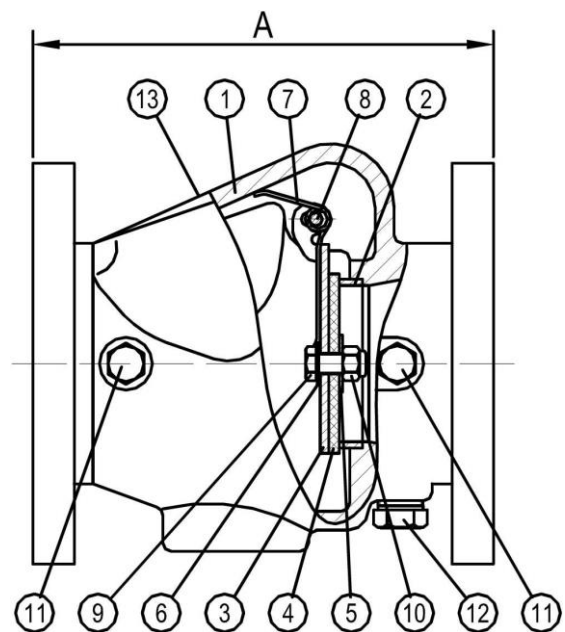

#### Dimension

Part Number	size		A		Weight	
	In.	mm	In.	mm	lbs	kg
VCF01-050	2	DN50	6.65	169	13.9	6.3
VCF01-065	2 1/2	DN65	7.20	183	20.3	9.2
VCF01-080	3	DN80	7.80	198	25.4	11.5
VCF01-100	4	DN100	8.58	218	40.4	18.3
VCF01-125	5	DN125	9.76	248	57.3	26
VCF01-150	6	DN150	10.63	270	69.5	31.5
VCF01-200	8	DN200	12.80	325	119	54

Flange Standard: ASME B16.5 Class150

BS 4504 PN10 / PN16

AS 2129 Table D / Table E

