



MECHANICAL TEE



- The coupling is ideally designed for use with Sch10 and Sch40 or BS steel pipe.
- The tongue and groove mechanism with build-in teeth provide rigidity in high flow and pressure pipeline.

Material Specifications:

- ◆ **Housing**
Ductile iron conforming to ASTM A536 Gr. 65-45-12



- ◆ **Rubber Gaskets**

| Gaskets Material | | General Service Recommendations | Color code |
|---|---------|---|------------------------|
|  | EPDM | EPDM is recognized as the most water resistant rubber available today. Good for cold & hot water up to 250°F (121°C), municipal water, waste water, deionized water. EPDM is not recommended for use with petroleum based oils and fuels, hydrocarbon solvents and aromatic hydrocarbons. EPDM gaskets for water services are not recommended for steam services unless coupling or components are accessible for frequent gasket replacement. | Black Green stripe |
|  | NITRILE | NBR, Buna-N, and Nitrile all represent the same copolymer of butadiene and acrylonitrile (ACN), which is inherently resistant to hydraulic fluids, lubricating oils, transmission fluids and other non-polar petroleum based products and water less than 150°F (65°C). The higher the ACN content, the higher the resistance to oils and heat, but the lower elastic characteristics and compression set. NBR displays poor resistance to hot water and steam. | Black Orange stripe |
|  | SILICON | Silicone (VMQ) FLO Grade "L" Silicone compound features high temperature range stability and low temperature flexibility. Recommended for dry heat and air without hydrocarbons up to 350°F (177°C). Silicone compounds are used in many food and medical applications as they do not impart odor or taste. Not recommended for hot water or steam services. | White |

Note: Only EPDM has FM approved & UL/ULC Listed.

- ◆ **Bolts & Nuts**

Heat treated, zinc electroplated, or galvanized oval neck track head bolts and hex nuts make of carbon steel in accordance with ASTM A183 (Metric in accordance with ISO 898).

Surface Finish:

Epoxy Coatings in RAL3000 red, available with hot dipped galvanized finish or orange painted.



MECHANICAL TEE

UM1 - Mechanical Tee

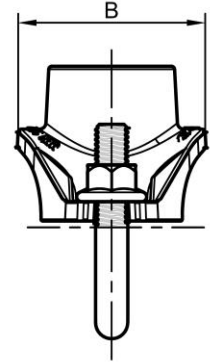
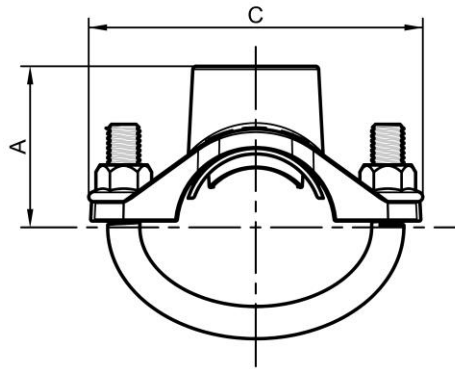
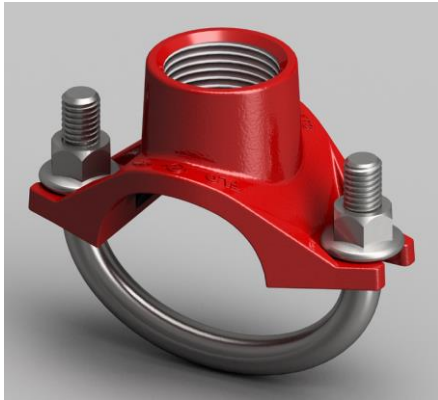

- ◆ The model UM1 mechanical tee is the ideal outlet fitting for making direct connections to sprinkler heads, drop nipples and or gauges.
- ◆ No need for welding just cut or drill a hole at the desired outlet location.



Dimension

| Nominal Size DN / NPS | Pipe O.D mm / in | Max. Work Pressure MPa / psi | Dimensions (mm / in) | | | Hole cut Dia mm / in | Weight kg / lbs |
|--------------------------|---|------------------------------------|----------------------|------------|-------------|-------------------------|--------------------|
| | | | A | B | C | | |
| 32 x 15 1 1/4" x 1/2" | 42.2 x 21.3 1.660 x 0.840 | 2.07 300 | 44 1.73 | 58 2.28 | 96 3.78 | 30.5 1.2 | 0.4 0.88 |
| 32 x 20 1 1/4" x 3/4" | 42.2 x 26.7 1.660 x 1.050 | 2.07 300 | 44 1.73 | 58 2.28 | 96 3.78 | 30.5 1.2 | 0.4 0.88 |
| 32 x 25 1 1/4" x 1" | 42.2 x 33.4 1.660 x 1.315 | 2.07 300 | 46 1.81 | 58 2.28 | 96 3.78 | 30.5 1.2 | 0.5 1.1 |
| 40 x 15 1 1/2" x 1/2" | 48.3 x 21.3 1.900 x 0.840 | 2.07 300 | 47 1.85 | 58 2.28 | 102 4.02 | 30.5 1.2 | 0.4 0.88 |
| 40 x 20 1 1/2" x 3/4" | 48.3 x 26.7 1.900 x 1.050 | 2.07 300 | 48 1.89 | 58 2.28 | 102 4.02 | 30.5 1.2 | 0.4 0.88 |
| 40 x 25 1 1/2" x 1" | 48.3 x 33.4 1.900 x 1.315 | 2.07 300 | 50 1.97 | 58 2.28 | 102 4.02 | 30.5 1.2 | 0.5 1.1 |
| 50 x 15 2" x 1/2" | 60.3 x 21.3 2.375 x 0.840 | 2.07 300 | 53 2.09 | 58 2.28 | 114 4.49 | 30.5 1.2 | 0.5 1.1 |
| 50 x 20 2" x 3/4" | 60.3 x 26.7 2.375 x 1.050 | 2.07 300 | 54 2.13 | 58 2.28 | 114 4.49 | 30.5 1.2 | 0.5 1.1 |
| 50 x 25 2" x 1" | 60.3 x 33.4 2.375 x 1.315 | 2.07 300 | 56 2.20 | 58 2.28 | 114 4.49 | 30.5 1.2 | 0.6 1.3 |
| 65 x 15 2 1/2" x 1/2" | 73.0(76.1) x 21.3 2.875(3.000) x 0.840 | 2.07 300 | 60 2.36 | 58 2.28 | 127 5.00 | 30.5 1.2 | 0.6 1.3 |
| 65 x 20 2 1/2" x 3/4" | 73.0(76.1) x 26.7 2.875(3.000) x 1.050 | 2.07 300 | 61 2.40 | 58 2.28 | 127 5.00 | 30.5 1.2 | 0.6 1.3 |
| 65 x 25 2 1/2" x 1" | 73.0(76.1) x 33.4 2.875(3.000) x 1.315 | 2.07 300 | 63 2.48 | 58 2.28 | 127 5.00 | 38.5 1.52 | 0.7 1.5 |