



PRESSURE GAUGE

PG01 - Pressure Gauge

- Suitable for Fire sprinkler systems
- Design: EN 837-1 & ASME B40.100
- Ranges: 0/300 psi (20bar), water or air
- UL Listed (UL-393)
- Ambient temperature: -40 ~ +60°C
- Maximum medium temperature: +60°C



Product Specifications

Size	4"(100mm)
Accuracy	ASME B40.100 Grade B ($\pm 3/2/3\%$ of span)
Case	Carbon steel with black painting or 304SS
Dial	White aluminum with stop pin; black and red lettering
Pointer	Black aluminum
Window	Tempered glass
Bourdon tube	C- shape; bronze
Movement	Brass
Socket	Brass
Connection	NPT1/4" or BSPT/BSPP1/4" Bottom or Back connection
Liquid filling	No

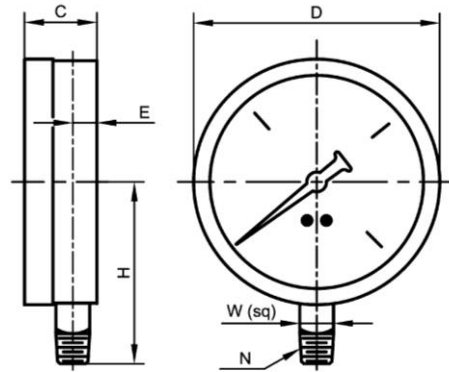

Bottom Connection

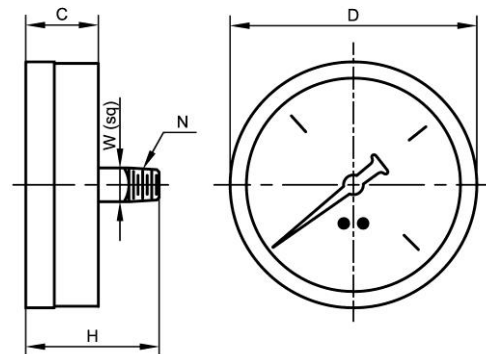

Back Connection



DIMENSIONS

Part Number	Connection	D	C	H	E	W	N
PG01-100-L1/4N	Bottom Connection	102	30	75	10	14	NPT1/4"
PG01-100-L1/4B							BSPT1/4"
PG01-100-L1/4G							BSPP1/4"
PG01-100-R1/4N	Back Connection	102	30	57	/	14	NPT1/4"
PG01-100-R1/4B							BSPT1/4"
PG01-100-R1/4G							BSPP1/4"