

FA1 - Grooved Flange

- ◆ NPS2" (DN50) through NPS12" (DN300)
- ◆ Directly incorporates ANSI Class125/150, PN10/16/25, bolt hole patterns into a grooved system.
- ◆ Material : ASTM A536 Gr. 65-45-12
- ◆ Groove dimension according: ANSI/AWWA C606
- ◆ Finish : Epoxy Coatings in RAL3000 red, available with hot dipped galvanized finish or orange painted.

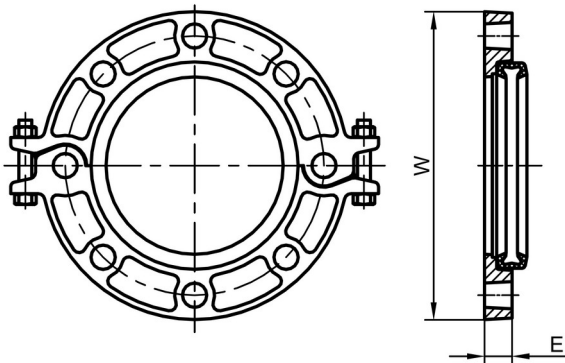

Hot dipped galvanized



Orange painted

Dimension

Nominal Size DN / NPS	Pipe O.D. mm / in	Max. Work Pressure MPa / psi	Application flange rating	E mm / in	W mm / in	Weight kg / lbs
50 2"	60.3 2.375	2.07 300	Class125/150 & PN10/16/25	22 0.87	165 6.50	1.63 3.59
65 2½"	73.0 2.875	2.07 300	Class125/150	22 0.87	178 7.01	1.95 4.30
65 3"O.D	76.1 3.000	2.07 300	PN10/16/25	22 0.87	185 7.28	1.95 4.30
80 3"	88.9 3.500	2.07 300	Class125/150 & PN10/16	22 0.87	200 7.87	2.24 4.94
100 4"	114.3 4.500	2.07 300	Class125/150 & PN10/16	24 0.95	229 9.01	2.75 6.06
125 5½"O.D	139.7 5.500	2.07 300	PN10/16	25 0.98	250 9.84	3.70 8.16
125 5"	141.3 5.563	2.07 300	Class125/150	25 0.98	255 10.04	3.80 8.38
150 6½"O.D	165.1 6.500	2.07 300	Class125/150 & PN10/16	25 0.98	285 11.22	4.60 10.14
150 6"	168.3 6.625	2.07 300	Class125/150 & PN10/16	25 0.98	285 11.22	4.60 10.14
200 8"	219.1 8.625	2.07 300	Class125/150 & PN10/16	28 1.10	343 13.50	7.60 16.76