

DE1 - Drain Elbow

- ◆ NPS2" (DN50) through NPS8" (DN200)
- ◆ Material: ASTM A536 Gr. 65-45-12
- ◆ Cut groove dimension according: ANSI/AWWA C606
- ◆ Finish: Epoxy Coatings in RAL3000 red, available with hot dipped galvanized finish or orange painted.

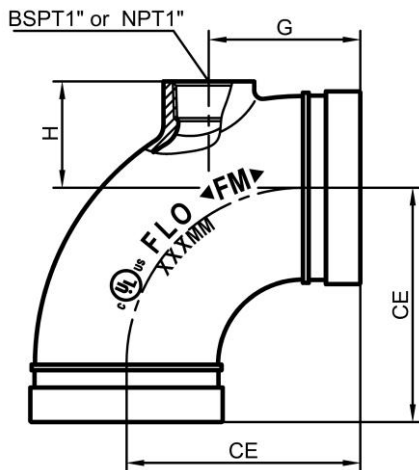

Hot dipped galvanized Orange painted

Dimension

Nominal Size DN / NPS	Pipe O.D mm / in	Max. Work Pressure MPa / psi	CE mm / in	H mm / in	G mm / in	Weight kg / lbs
50 2"	60.3 2.375	2.07 300	83 3.27	40 1.57	57 2.24	0.90 1.98
65 2 1/2"	73.0 2.875	2.07 300	95 3.74	40 1.57	70 2.76	1.30 2.87
65 3" O.D	76.1 3.000	2.07 300	95 3.74	40 1.57	70 2.76	1.30 2.87
80 3"	88.9 3.500	2.07 300	108 4.25	49 1.93	70 2.76	1.80 3.97
100 4"	114.3 4.500	2.07 300	127 5.00	63 2.48	70 2.76	2.75 6.06
125 5 1/2" O.D	139.7 5.500	2.07 300	140 5.51	76 2.99	70 2.76	3.90 8.60
125 5"	141.3 5.563	2.07 300	140 5.51	76 2.99	70 2.76	3.95 8.71
150 6 1/2" O.D	165.1 6.500	2.07 300	165 6.50	90 3.54	70 2.76	6.30 13.89
150 6"	168.3 6.625	2.07 300	165 6.50	90 3.54	70 2.76	6.60 14.55
200 8"	219.1 8.625	2.07 300	197 7.756	114 4.49	84 3.31	12.10 26.68