

### PR03 - Roller Support

**Size Range:** 2" through 36"

**Material:** Cast iron & Carbon steel

**Finish:** Hot-dip galvanizing, other finish available upon request

**Service:**

- For suspension of pipe from two rods where longitudinal expansion and contraction may occur

**Approvals:**

- Complies with Federal Specification A-A-1192A (Type 41)  
WW-H-171-E (Type 42) and MSS-SP-58 (Type 41).

**Ordering:** Specify Part Number

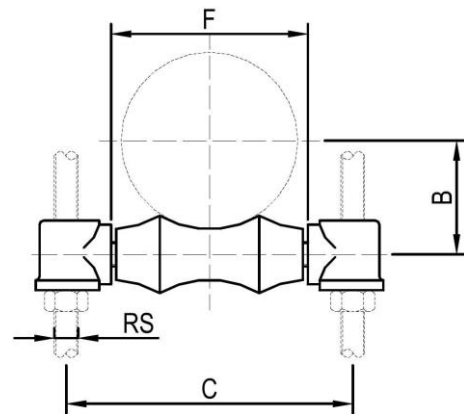
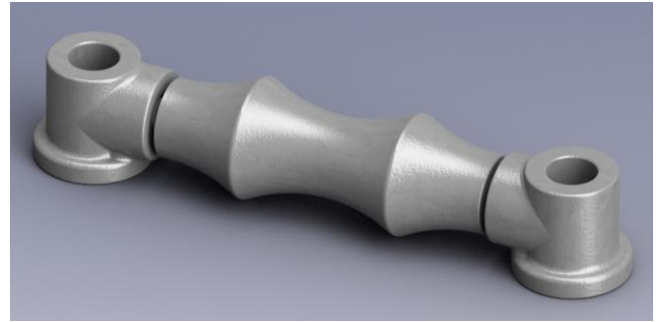

Part Number (HDG)	Nominal Pipe Size		RS		B		F		C		Wt.		Max. Rec. Load	
	in.	mm	in.	mm	in.	mm	in.	mm	in.	mm	lb	kg	lbs	KN
PR03H-050	2	DN50	3/8	M10	1.63	41	2.75	70	4.02	102	0.6	0.27	600	2.67
PR03H-065	2½	DN65	1/2	M12	2.00	51	3.25	83	5.00	127	1.0	0.45	660	2.94
PR03H-080	3	DN80	1/2	M12	2.25	57	3.88	99	5.63	143	1.1	0.50	700	3.12
PR03H-100	4	DN100	5/8	M16	2.75	70	4.94	125	6.30	176	1.7	0.77	750	3.34
PR03H-125	5	DN125	5/8	M16	3.50	89	6.00	152	7.99	203	2.6	1.2	750	3.34
PR03H-150	6	DN150	3/4	M20	4.00	102	7.13	181	9.65	245	4.5	2.0	1070	4.76
PR03H-200	8	DN200	7/8	M22	5.13	130	9.05	230	11.81	300	7.2	3.3	1350	6.00
PR03H-250	10	DN250	7/8	M22	6.38	162	11.25	286	14.02	356	9.5	4.3	1730	7.70
PR03H-300	12	DN300	7/8	M22	7.50	191	13.25	337	15.75	407	16	7.3	2400	10.70
PR03H-350	14	DN350	1	M24	8.38	213	14.50	368	17.52	445	24	11	3130	14.00
PR03H-400	16	DN400	1	M24	9.50	241	16.50	419	19.49	495	32	15	3970	17.70
PR03H-450	18	DN450	1	M24	10.50	267	18.50	470	21.50	546	36	16	4200	18.70
PR03H-500	20	DN500	1¼	M30	11.63	295	20.50	521	24.25	616	47	21	4550	20.20
PR03H-550	22	DN550	1¼	M30	13.58	345	22.44	570	26.18	665	63	29		
PR03H-600	24	DN600	1½	M39	13.81	351	24.63	626	28.63	727	76	35	6160	27.40
PR03H-750	30	DN750	2	M52	17.24	438	30.51	775	35.51	902	35.5	78	7290	32.43
PR03H-900	36	DN900	2¼	M56	20.59	523	36.61	930	42.36	1076				