



# PIPE ROLLER

## PR02 - Roller Chair

**Size Range:** 2" through 36"

**Material:** Cast iron & Carbon steel

**Finish:** Hot-dip galvanizing, other finish available upon request

**Service:**

- For support of pipe where longitudinal movement due to expansion and contraction may occur, but where no vertical adjustment is required.

**Approvals:**

- Complies with Federal Specification A-A-1192A (Type 44)  
WW-H-171-E (Type 45) and MSS-SP-69 (Type 44).

**Ordering:** Specify Part Number

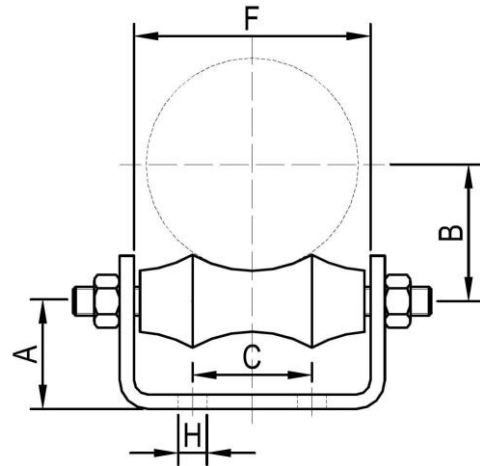
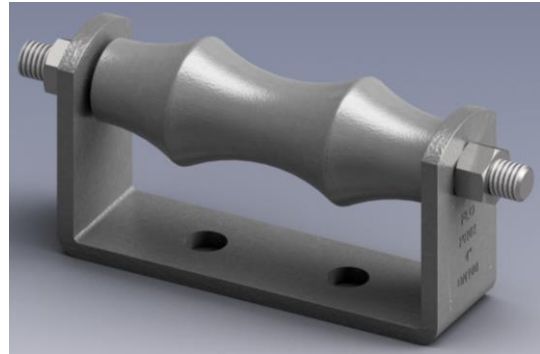

Part Number (HDG)	Nominal Pipe Size		H		A		B		C		F		Wt.		Max. Rec. Load	
	in.	mm	in.	mm	in.	mm	in.	mm	in.	mm	in.	mm	lb	kg	lbs	kN
PR02H-050	2	DN50	0.47	12	1.57	40	1.63	41	1.18	30	2.75	70	1.0	0.45	600	2.67
PR02H-065	2½	DN65	0.47	12	1.57	40	2.00	51	1.18	30	3.25	83	1.3	0.60	600	2.67
PR02H-080	3	DN80	0.47	12	1.77	45	2.25	57	1.97	50	3.88	99	1.5	0.68	600	2.67
PR02H-100	4	DN100	0.55	14	2.56	65	2.75	70	1.97	50	4.94	125	2.6	1.18	700	3.12
PR02H-125	5	DN125	0.55	14	2.56	65	3.50	89	2.76	70	6.00	152	3.4	1.54	700	3.12
PR02H-150	6	DN150	0.55	14	2.75	70	4.00	102	3.15	80	7.13	181	5.5	2.50	1000	4.45
PR02H-200	8	DN200	0.71	18	2.95	75	5.13	130	3.15	80	9.05	230	8.4	3.81	1300	5.78
PR02H-250	10	DN250	0.71	18	3.54	90	6.38	162	5.12	130	11.25	286	13	5.90	1700	7.56
PR02H-300	12	DN300	0.71	18	3.94	100	7.50	191	5.51	140	13.25	337	18	8.17	2300	10.20
PR02H-350	14	DN350	0.71	18	4.53	115	8.38	213	6.29	160	14.50	368	27	12.3	3100	13.80
PR02H-400	16	DN400	0.71	18	5.12	130	9.50	241	7.87	200	16.50	419	33	15.0	3900	17.30
PR02H-450	18	DN450	0.71	18	5.51	140	10.50	267	9.45	240	18.50	470	42	19.0	4200	18.70
PR02H-500	20	DN500	0.78	20	5.51	140	11.63	295	9.84	250	20.50	521	54	24.5	4500	20.00
PR02H-550	22	DN550	0.78	20	6.69	170	13.58	345	11.8	300	22.44	570	70	31.7	5000	22.20
PR02H-600	24	DN600	0.78	20	6.69	170	13.81	351	11.8	300	24.63	626	85	38.6	6000	26.70
PR02H-750	30	DN750	1.02	26	7.48	190	17.24	438	14.96	380	31.3	795			7290	32.40
PR02H-900	36	DN900	1.18	30	9.25	235	20.59	523	18.11	460	37.4	950			11000	48.90