

# CRD02 – CORRODE-INCATOR

- The CRD02 Corrode-incator with pressure switch is designed to provide early stage warning to the corrosion-related failures in both wet and dry steel sprinkler piping.
- The CRD02's pressure switch operates to indicate the corrosion related steel pipe failure in progress.
- Applicable Pipe Size: 2" ~ 8"
- Service Pressure: 300 PSI
- Operating Temp.: -40 ~ 90°C
- Material: Carbon Steel
- Pressure switch: Parameters as shown in the catalog of model DPS01

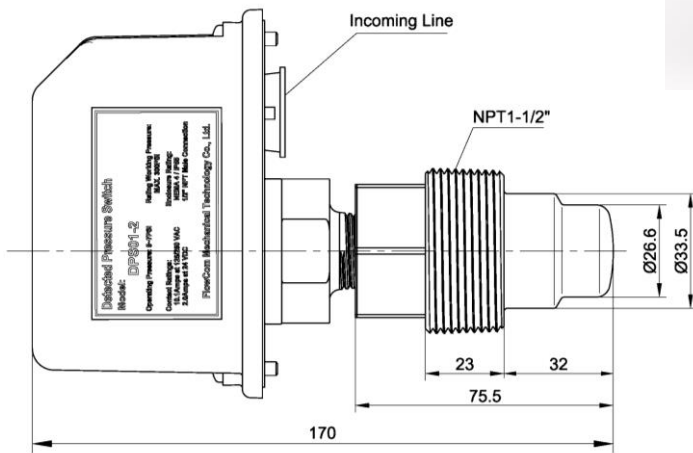

## ◆ Installation and Orientation

The CRD02 Corrode-incator can be installed virtually anywhere on a wet or dry fire system with a mechanical tee (supplied separately). Recommended installation sites include high points of water mains, at the end of branch lines, or where corrosion has been a problem. When installing horizontally on a wet system, the indicator should be facing up at approximately 45° (dark blue area), and on a dry system the indicator should face down at approximately 45° (light blue area).

