

SSB0303 – Quick Bracing Clamp

- **Function** : For bracing pipe against sway and seismic disturbance. Provides an easy lateral connection joining brace member and pipe together as a complete assembly.
- **Pipe Size**: To be braced 1" ~ 8" pipe.
- **Brace members**: 1" Sch.40 pipe for 1" ~ 8" System piping or 1-1/4" Sch.40 pipe for 2.5" ~ 8" System piping.
- **Finish**: Zinc plated. Other finishes upon request.
- **Material**: Carbon steel
- **Installation**: Place over the pipe to be braced, and insert brace member through opening leaving a minimum 1" (for pipe size less than 4") or 2" (for pipe size of 4" and above) extending from attachment. Must leave a minimum of 6" away from a pipe joint.
- **Approvals**: Comply with NFPA 13 and GB 50981.
UL/ULC Listed.

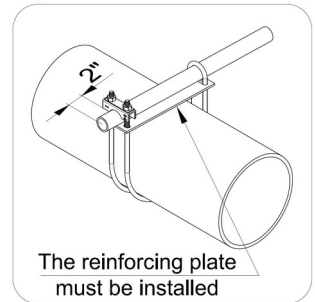
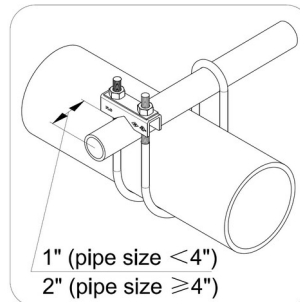
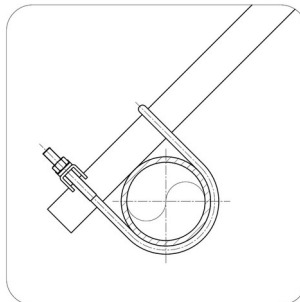
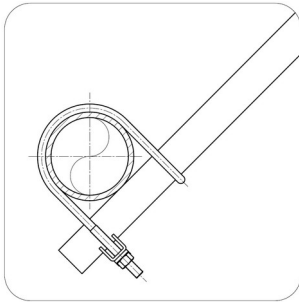

Size: 1" ~ 6"

Size: 8"



Pipe Size		UL Max. Design Load lbs. (kN)	Weight			
NPS	DN		1" Sch.40 Brace member		1-1/4" Sch.40 Brace member	
			lbs.	kg	lbs.	kg
1"	25	680 (3.02)	0.75	0.34	/	/
1-1/4"	32	680 (3.02)	0.79	0.36	/	/
1-1/2"	40	680 (3.02)	0.84	0.38	/	/
2"	50	680 (3.02)	0.90	0.41	/	/
2-1/2"	65	680 (3.02)	0.97	0.44	1.01	0.46
3"	80	680 (3.02)	1.04	0.47	1.04	0.47
4"	100	680 (3.02)	1.19	0.54	1.19	0.54
5"	125	1090 (4.85)	1.32	0.60	1.37	0.62
6"	150	1090 (4.85)	1.46	0.66	1.50	0.68
8"	200	1370 (6.09)	3.26	1.48	3.31	1.50