

Fire Alarm Equipment

GSS01 – OS&Y Supervisory Switch

- Contact Ratings: One set SPDT (Form C)
10.1 Amps at 125/250 VAC
2.0 Amps at 24 VDC
- Operating Temperature Range: 40 °F to 140 °F (4 °C to 60 °C)
- Enclosure Rating: NEMA 4 - suitable for indoor/outdoor use
*** For outdoor use please use suitably rated conduit and connector.
- Visual switch indicators
- Adjustable length actuating lever
- Accommodates up to 12 AWG wire
- Three position switch monitors vandal and valve closure signals
- Conduit Entrances: One opening for 1/2" conduit
- Service Use:
Automatic Sprinkler: NFPA-13
One or Two Family Dwelling: NFPA-13D
Residential Occupancies up to 4 stories: NFPA-13R
National Fire Alarm Code: NFPA-72
- Cover Material: Aluminum Die-casting. Alternative Material Plastic



Field Typical Electrical Connections

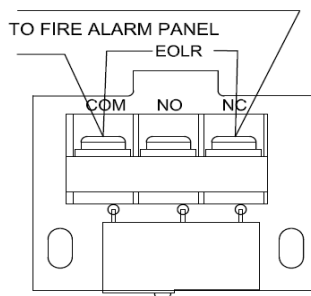

Model and Size:

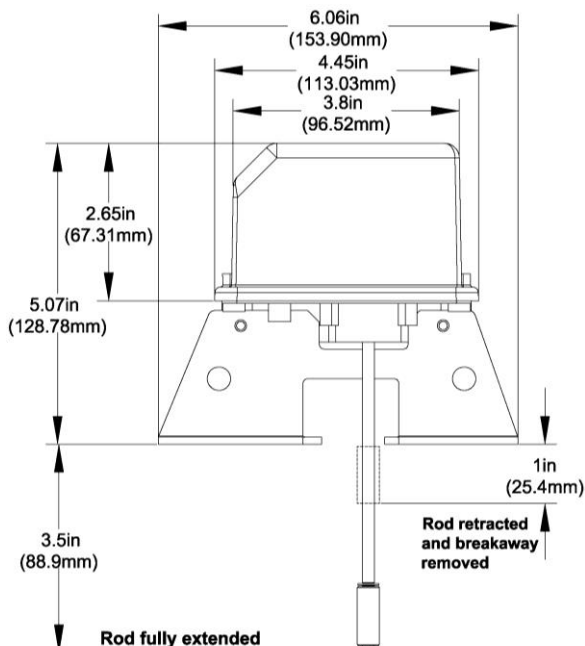

Model	Description	Weight(kg)
GSS01	One set SPDT contacts	0.75