

SSB0102 – Beam Attachment

- **Function:** Attach a sway bracing assembly to a steel bar joist or structural member up to 0.71" (18 mm).
- **Size:** One size fits braced pipe up to 8". Attaches to structural members up to 0.71" (18 mm) thick.
- **Finish:** Zinc plated, Other finishes upon request.
- **Material:** Ductile iron
- **Installation:** It needs to be installed within 6" of chord panel point. Place on structural member with the flange contacting the back of the jaw. Tighten set screws finger tight, then evenly tighten until hex heads break off. Attach sway bracing attachment SSB0101C(S) to SSB0102.
- **Qualification:** Comply with NFPA 13 and GB 50981, UL listed.
- **Max Load (Lateral and Longitudinal):** 1370lbs. (6.09kN).

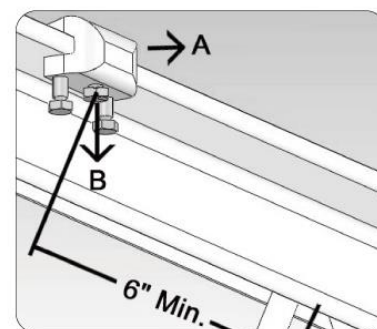
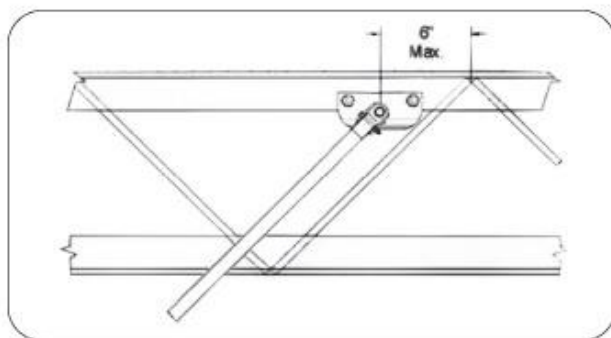
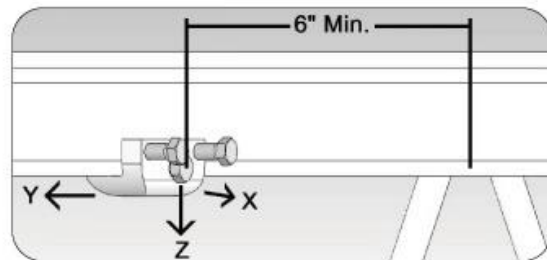
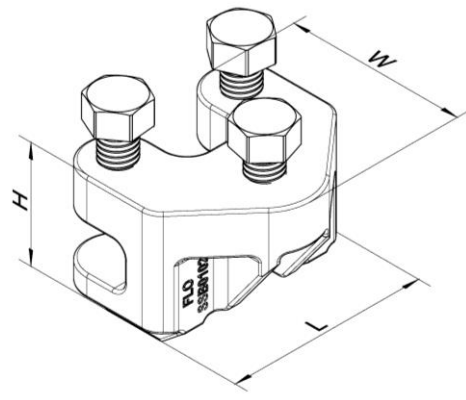
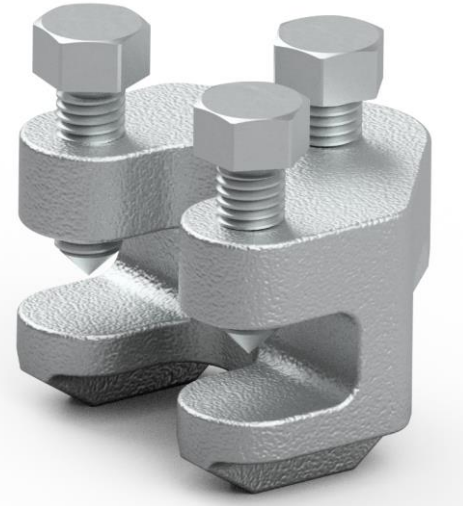

Dimensions

Model No.	L	W	H
SSB0102	77	67	53