

# SWAY BRACE COMPONENTS

## SSB0101S – Structural Attachment

- **Function:** Multi-functional attachment to building structure or braced pipe clamps. Designed to use 1” or 1-1/4” SCH 40 pipe as brace member.
- **Size:** One size fits braced pipe up to 8”, with 1/2” bolt hole for structure.
- **Finish:** Zinc plated. Other finishes upon request.
- **Material:** Carbon steel and ductile iron.
- **Installation :** SSB0101S is the structural or transitional attachment component of a longitudinal or lateral sway bracing assembly. To install, insert the brace member into the clamp, and tighten the break-off bolt until the hex head breaks off.
- **Approvals:** Comply with NFPA 13 and GB 50981  
UL/ULC Listed.

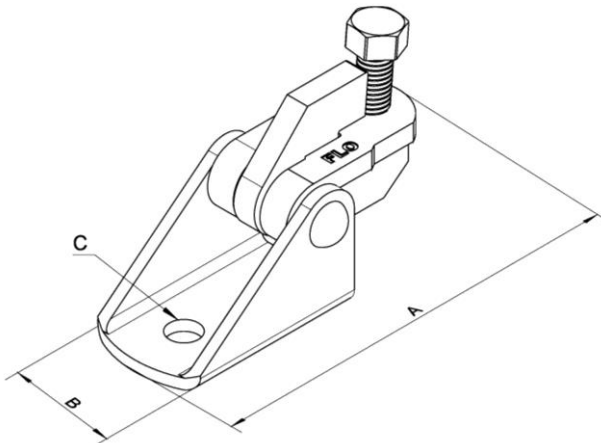

**Dimensions**

Model No.	A		B		C		Wt.	
	in.	mm	in.	mm	in.	mm	lbs	kg
SSB0101S	5.16	131	2.05	52	0.55	14	1.61	0.73

**UL Maximum Design Load**

Brace member	lbs.	kN
1” or 1-1/4” SCH40	2015	8.96

