

Triplicate-gate Dry Barrel Fire Hydrants

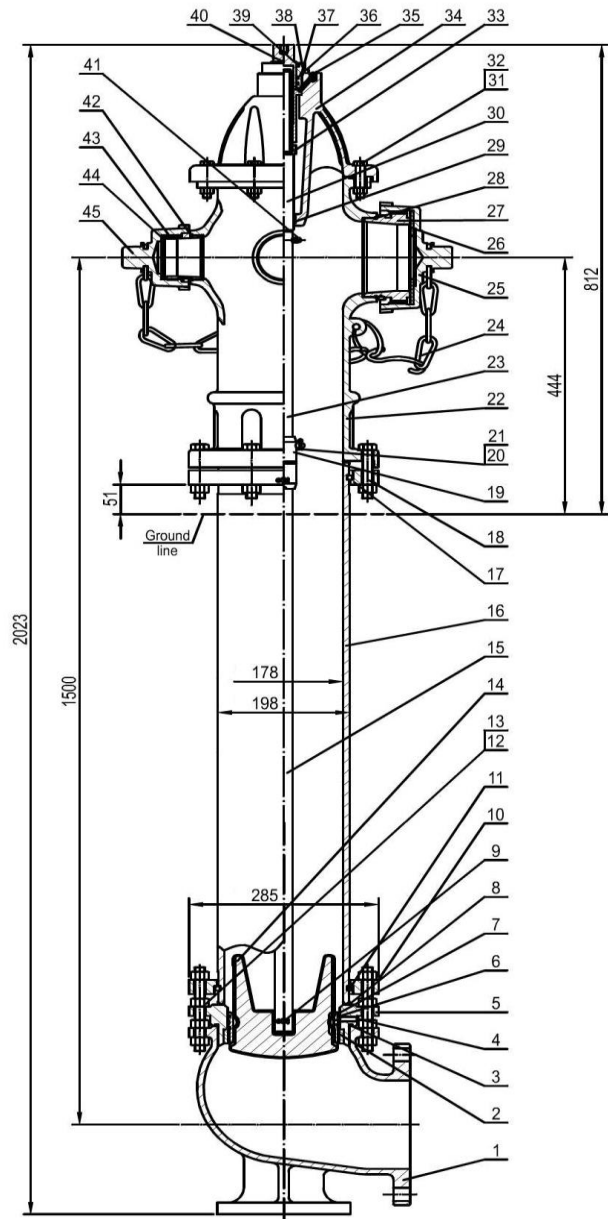

Material Specifications

PART	SPECIFICATION	PART	SPECIFICATION	PART	SPECIFICATION
1. Hydrant Body	ASTM A536	16. Barrel	ASTM A536	31. Hex Nuts	ASTM A574
2. Seal-ring	ASTM B584	17. Breakable Flange	ASTM A126B	32. Screw	ASTM A574
3. O-ring	EPDM	18. Bolts	ASTM A574	33. Stop Nut	45#
4. Scrwed Plug	ASTM B584	19. Coupling	ASTM A536	34. Hydrant Bonnet	ASTM A536
5. Main Valve Flange	ASTM A536	20. Pin Axes	SS304	35. Oil Cup	
6. O-ring	EPDM	21. Pin	SS304	36. O-ring	EPDM
7. Valve Seat	ASTM B584	22. Drainpipe	ASTM A536	37. O-ring	EPDM
8. Barrel Gasket	EPDM	23. Up Stem	ASTM A574M	38. Bush	ASTMB16-H02 C36000
9. Pin Axes	SS304	24. Link		39. Dustproof Ring	EPDM
10. Lower Flange	ASTM A536	25. Big Nozzle Cap	ASTM A536	40. Stem Nut	ASTM B584
11. Lock Ring	SS304	26. Big Sealed Gasket	EPDM	41. Pin Axes	SS304
12. Hex Nuts	ASTM A574	27. Big Outlet	ASTM B584	42. O-ring	EPDM
13. Stud Bolts	ASTM A574	28. O-ring	EPDM	43. Small Outlet	ASTM B584
14. Wedge	ASTM A536 with EPDM	29. O-ring	EPDM	44. Small Sealed Gasket	EPDM
15. Lower Stem	ASTM A574M	30. Stem	SS410	45. Small Nozzle Cap	ASTM A536